

# 1610 - RCS, Lifting Capacity Chart, K1

	<b>IOWA MOLD TOOLING CO., INC.</b> <b>BOX 189 • GARNER • IA • 50438 • 641-923-3711</b>
<h2 style="margin: 0;">Model 1610 RCS K1</h2>	<ul style="list-style-type: none"> <li>● Limit working loads to those shown. Deduct the weight of load handling devices.</li> <li>● <i>El peso propio (tara) de los dispositivos de manipulación de cargas es parte de la carga levantada y se debe descontar de la capacidad nominal.</i></li> </ul>

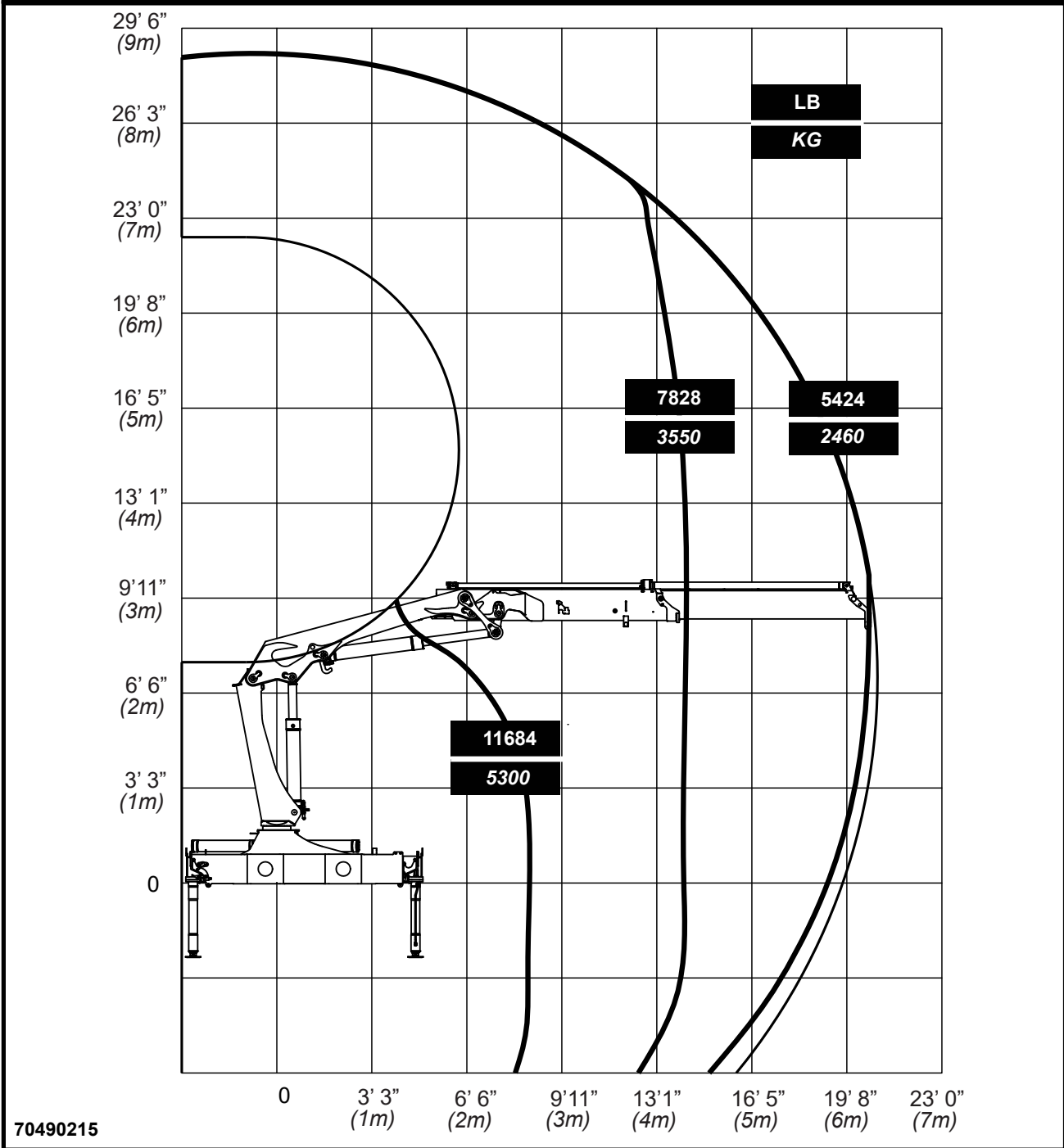

70490215